

0163127en	005
1007	

Generator

GP 5600A

GPS 5600A

OPERATOR'S MANUAL



1. Foreword	5
2. California Evaporative Emission Control Warranty Statement	6
3. Safety Information	8
3.1 Laws Pertaining to Spark Arresters	8
3.2 Operating Safety	9
3.3 Operator Safety while using Internal Combustion Engines	10
3.4 Service Safety	12
3.5 Label Locations	13
3.6 Safety and Operating Labels	14
4. Technical Data	19
4.1 Generator	19
4.2 Engine	21
5. Operation	22
5.1 Determining Power Requirements	22
5.2 Outdoor Installation	23
5.3 Indoor Installation	23
5.4 Recommended Battery (GPS only)	23
5.5 Battery Tray Installation (GPS only)	24
5.6 Wheel Kit	25
5.7 Generator Derating	27
5.8 Grounding the Generator	28
5.9 Operating Heavy Loads	28
5.10 Use of Extension Cords	29
5.11 Control Panel	30
5.12 Ground Fault Circuit Interrupter (GFCI)	31
5.13 Twist Lock Receptacles	32
5.14 Engine Auto Idle	32
5.15 Engine Speed	32
5.16 Voltage Selection	33
5.17 Before Starting	34
5.18 To Start	35
5.19 To Stop	36

6.	Maintenance	37
6.1	Engine Maintenance	37
6.2	Periodic Maintenance Schedule	37
6.3	Engine Oil	38
6.4	Servicing Air Cleaner	39
6.5	Spark Plug	40
6.6	Cleaning the Sediment Cup	41
6.7	Carburetor Adjustment	42
6.8	Adjusting Engine Speed	42
6.9	Storage	43
6.10	Transport	43
6.11	Troubleshooting	44
6.12	Wire Colors	44
6.13	Electrical Schematic	46
6.14	Electrical Schematic (CAN models only)	48
6.15	Engine Schematic	50

CALIFORNIA

Proposition 65 Warning:



Engine exhaust, some of its constituents, and certain vehicle components, contain or emit chemicals known to the State of California to cause cancer and birth defects or other reproductive harm.

1. Foreword

This manual provides information and procedures to safely operate and maintain this Wacker model. For your own safety and protection from injury, carefully read, understand and observe the safety instructions described in this manual.

Keep this manual or a copy of it with the machine. If you lose this manual or need an additional copy, please contact Wacker Corporation. This machine is built with user safety in mind; however, it can present hazards if improperly operated and serviced. Follow operating instructions carefully! If you have questions about operating or servicing this equipment, please contact Wacker Corporation.

The information contained in this manual was based on machines in production at the time of publication. Wacker Corporation reserves the right to change any portion of this information without notice.

All rights, especially copying and distribution rights, are reserved.

Copyright 2007 by Wacker Corporation.

No part of this publication may be reproduced in any form or by any means, electronic or mechanical, including photocopying, without express written permission from Wacker Corporation.

Any type of reproduction or distribution not authorized by Wacker Corporation represents an infringement of valid copyrights and will be prosecuted. We expressly reserve the right to make technical modifications, even without due notice, which aim at improving our machines or their safety standards.

California Evaporative Emission Control Warranty Statement

2. California Evaporative Emission Control Warranty Statement

YOUR WARRANTY RIGHTS AND OBLIGATIONS

The California Air Resources Board and Wacker Corporation, Inc. are pleased to explain the evaporative emission control system (EECS) warranty on your model year 2006 and later portable generator. In California, new portable generators must be designed, built and equipped to meet the State's stringent anti-smog standards. Wacker Corporation must warrant the EECS on your portable generator for the period of time listed below provided there has been no abuse, neglect or improper maintenance of your portable generator.

Your EECS on your model year 2006 and later portable generator includes the fuel line, fuel line clamps and fuel line fittings.

Where a warrantable condition exists, Wacker Corporation will repair your portable generator at no cost to you including diagnosis, parts and labor.

MANUFACTURER'S WARRANTY COVERAGE:

This EECS is warranted for two years from the initial date of purchase. If any evaporative emission-related part on your equipment is defective, the part will be repaired or replaced by Wacker Corporation at no charge to you. The owner shall not be charged for diagnostic labor that leads to determination that a warranted part is in fact defective, provided that such diagnostic work is performed at a Wacker Corporation's authorized service center.

WARRANTY PERIOD:

Any warranted part that is not scheduled for replacement as required maintenance, or which is scheduled only for regular inspection to the effect of "repair or replace as necessary" shall be warranted for two years. Any warranted part that is scheduled for replacement as required maintenance shall be warranted for a time not less than the remaining warranty period.

California Evaporative Emission Control Warranty Statement

OWNER'S WARRANTY RESPONSIBILITIES:

As the portable generator owner, you are responsible for performance of the required maintenance listed in your owner's manual. Wacker Corporation recommends that you retain all receipts covering maintenance on your portable generator, but Wacker Corporation cannot deny warranty solely for the lack of receipts.

As the portable generator owner, you should however be aware that Wacker Corporation may deny you warranty coverage if your portable generator or a part has failed due to abuse, neglect, or improper maintenance or unapproved modifications.

You are responsible for presenting your portable generator to Wacker Corporation's authorized service center as soon as the problem exists. The warranty repairs should be completed in a reasonable amount of time, not to exceed 30 days. If you have a question regarding your warranty coverage, you should contact your nearest authorized Wacker service center or call 1-800-770-0957.

WHAT IS NOT COVERED:

All failures caused by abuse, neglect, or improper maintenance are not covered. In addition, the use of add-on or modified parts will be grounds for disallowing a warranty claim.

WARRANTED PARTS:

The repair or replacement of any warranted part otherwise eligible for warranty coverage may be excluded from such warranty coverage if Wacker Corporation demonstrates that the portable generator has been abused, neglected, or improperly maintained, and that such abuse, neglect, or improper maintenance was the direct cause of the need for repair or replacement of the part. That notwithstanding, any adjustment of a component that has a factory installed, and properly operating, adjustment limiting device is still eligible for warranty coverage. The following emission warranty parts list is covered:

- (1) Fuel Line.
- (2) Fuel Line Clamps.
- (3) Fuel Line Fittings.

3. Safety Information

This manual contains DANGER, WARNING, CAUTION, *NOTICE* and NOTE callouts which must be followed to reduce the possibility of personal injury, damage to the equipment, or improper service.



This is the safety alert symbol. It is used to alert you to potential personal injury hazards. Obey all safety messages that follow this symbol to avoid possible injury or death.



DANGER

DANGER indicates a hazardous situation which, if not avoided, will result in death or serious injury.



WARNING

WARNING indicates a hazardous situation which, if not avoided, could result in death or serious injury.



CAUTION

CAUTION indicates a hazardous situation which, if not avoided, could result in minor or moderate injury.

NOTICE: Used without the safety alert symbol, **NOTICE** indicates a hazardous situation which, if not avoided, could result in property damage.

Note: *Contains additional information important to a procedure.*

3.1 Laws Pertaining to Spark Arresters

Notice: State Health Safety Codes and Public Resources Codes specify that in certain locations spark arresters be used on internal combustion engines that use hydrocarbon fuels. A spark arrester is a device designed to prevent accidental discharge of sparks or flames from the engine exhaust. Spark arresters are qualified and rated by the United States Forest Service for this purpose.

In order to comply with local laws regarding spark arresters, consult the engine distributor or the local Health and Safety Administrator.

3.2 Operating Safety



DANGER

BACKFEED FROM THE GENERATOR INTO THE PUBLIC POWER DISTRIBUTION SYSTEM CAN CAUSE SERIOUS INJURY OR DEATH TO UTILITY WORKERS!

Improper connection of generator to a building's electrical system can allow electrical current from the generator to backfeed into utility lines. This may result in electrocution of utility workers, fire, or explosion. Connections to a building's electrical system must be made by a qualified electrician and comply with all applicable laws and electrical codes.

If connected to a building's electrical system the generator must meet the power, voltage, and frequency requirements of the equipment in the building. Differences in power, voltage, and frequency requirements may exist and improper connection may lead to equipment damage, fire, and personal injury or death.



WARNING

Familiarity and proper training are required for the safe operation of the machine. Machines operated improperly or by untrained personnel can be dangerous. Read the operating instructions contained in both this manual and the Engine Manual and familiarize yourself with the location and proper use of all controls. Inexperienced operators should receive instruction from someone familiar with the machine before being allowed to operate it.

- 3.2.1 NEVER operate the generator when open containers of fuel, paint, or other flammable liquids are near.
- 3.2.2 NEVER operate the generator, or tools attached to the generator, with wet hands.
- 3.2.3 NEVER use worn electrical cords. Severe electrical shock and equipment damage may result.
- 3.2.4 NEVER run the electrical cords under the generator, or over vibrating or hot parts.
- 3.2.5 NEVER enclose or cover the generator when it is in use or when it is hot.
- 3.2.6 NEVER overload the generator. The total amperage of the tools and equipment attached to the generator must not exceed the load rating of the generator.
- 3.2.7 NEVER operate the machine in snow, rain, or standing water.
- 3.2.8 NEVER allow untrained personnel to operate or service the generator. The generator set should be set up by a certified electrician.
- 3.2.9 NEVER stand on the machine.
- 3.2.10 DO NOT stand under the machine while it is being hoisted or moved.
- 3.2.11 DO NOT attach equipment to the machine when it is suspended.

- 3.2.12 ALWAYS store the machine properly when it is not being used. The machine should be stored in a clean, dry location out of the reach of children.
- 3.2.13 ALWAYS position and operate the generator on a firm, noncombustible, level surface.
- 3.2.14 ALWAYS transport the generator in an upright position.
- 3.2.15 ALWAYS keep the machine at least one meter (three feet) away from structures, buildings, and other equipment during use.
- 3.2.16 ALWAYS keep the area immediately surrounding and underneath the machine clean, neat, and free of debris and combustible materials. Make sure that the area overhead is clear of debris that could fall onto or into the machine or exhaust compartment.
- 3.2.17 ALWAYS remove all tools, cords, and other loose items from the generator before starting it.
- 3.2.18 ALWAYS make certain the machine is well-grounded and securely fastened to a good earthen ground per national and local regulations.

3.3 Operator Safety while using Internal Combustion Engines



- Internal combustion engines present special hazards during operation and fueling. Read and follow the warning instructions in the engine Owner's Manual and the safety guidelines below. Failure to follow the warnings and safety standards could result in severe injury or death.
- 3.3.1 DO NOT run the machine indoors or in an enclosed area such as a deep trench unless adequate ventilation, through such items as exhaust fans or hoses, is provided. Exhaust gas from the engine contains poisonous carbon monoxide gas; exposure to carbon monoxide can cause loss of consciousness and may lead to death.
 - 3.3.2 DO NOT smoke while operating the machine.
 - 3.3.3 DO NOT smoke when refueling the engine.
 - 3.3.4 DO NOT refuel a hot or running engine.
 - 3.3.5 DO NOT refuel the engine near an open flame.
 - 3.3.6 DO NOT spill fuel when refueling the engine.
 - 3.3.7 DO NOT run the engine near open flames.
 - 3.3.8 DO NOT start the engine if fuel has spilled or a fuel odor is present. Move the generator away from the spill and wipe the generator dry before starting.
 - 3.3.9 ALWAYS refill the fuel tank in a well-ventilated area.
 - 3.3.10 ALWAYS replace the fuel tank cap after refueling.

- 3.3.11 ALWAYS check the fuel lines and the fuel tank for leaks and cracks before starting the engine. Do not run the machine if fuel leaks are present or the fuel lines are loose.

3.4 Service Safety



Poorly maintained equipment can become a safety hazard! In order for the equipment to operate safely and properly over a long period of time, periodic maintenance and occasional repairs are necessary. If the generator is experiencing problems or is being serviced, attach a “DO NOT START” sign to the control panel to notify other people of its condition.

- 3.4.1 DO NOT use gasoline or other types of fuels or flammable solvents to clean parts, especially in enclosed areas. Fumes from fuels and solvents can become explosive.
- 3.4.2 DO NOT attempt to clean or service the machine while it is running.
- 3.4.3 DO NOT modify the machine without the express written approval of the manufacturer.
- 3.4.4 DO NOT allow water to accumulate around the base of the machine. If water is present, move the machine and allow the machine to dry before servicing.
- 3.4.5 DO NOT service the machine if your clothing or skin is wet.
- 3.4.6 DO NOT allow untrained personnel to service this equipment. Only trained electrical technicians should be allowed to service the electrical components of this equipment.
- 3.4.7 ALWAYS keep the machine clean and labels legible. Replace all missing and hard-to-read labels. Labels provide important operating instructions and warn of dangers and hazards.
- 3.4.8 ALWAYS replace the safety devices and guards after repairs and maintenance.
- 3.4.9 ALWAYS let the engine cool before transporting or servicing it.
- 3.4.10 ALWAYS keep hands, feet, and loose clothing away from the moving parts on the generator and engine.
- 3.4.11 ALWAYS turn the engine off before servicing the machine. If the engine has electric start, disconnect the negative terminal on the battery before servicing the machine.
- 3.4.12 ALWAYS keep the fuel lines in good condition and properly connected. Leaking fuel and fumes are extremely explosive.

3.5 Label Locations



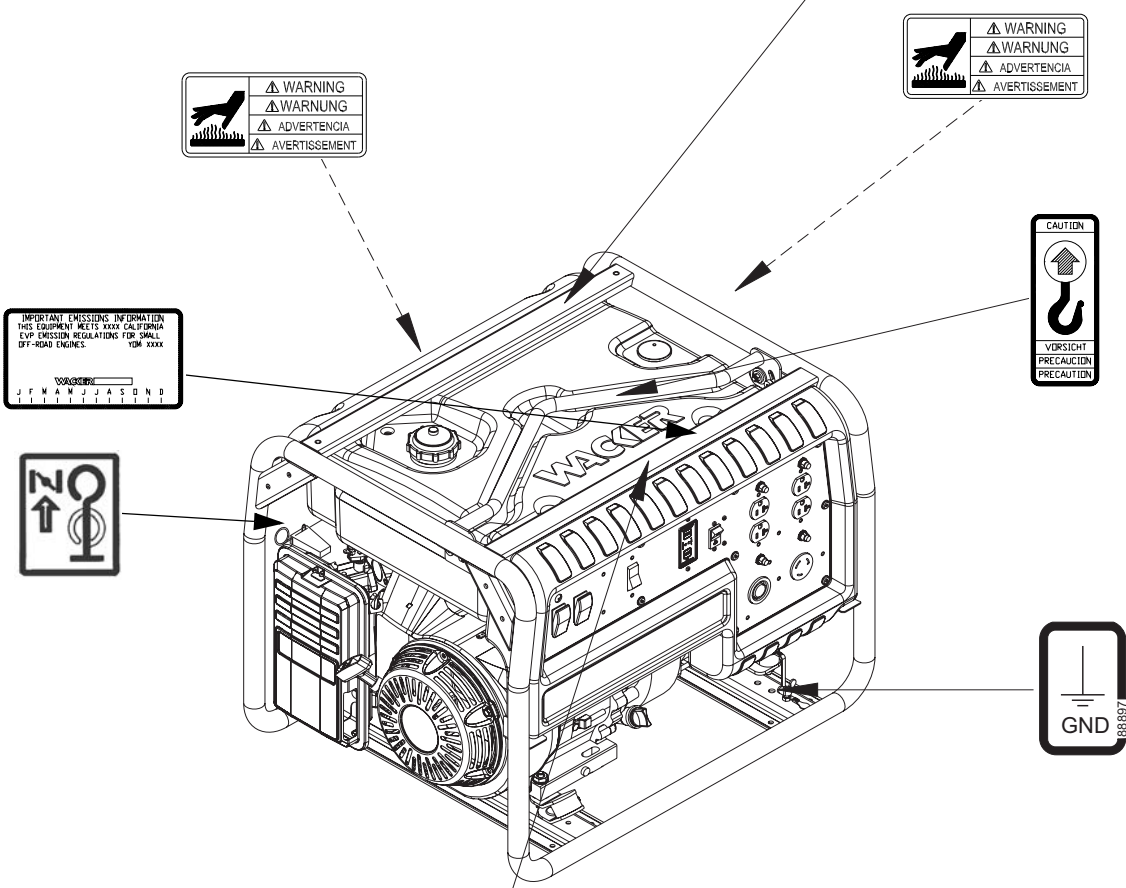

<p>⚠ DANGER</p> <p>⚠ PELIGRO</p> <p>⚠ DANGER</p>		<p>GP/GP TEST INSTRUCTIONS - TEST BEFORE EACH USE</p> <p>NORMAL OPERATING STATE - STOPPING IN CASE OF OVERLOAD IS OK AND CANNOT BECAUSE OF AN "OVERLOAD"</p> <p>STEP 1 - PRESS TEST BUTTON, WATCHES POWER LED STOP AND RED LED FLASHES FOUR TIMES AND BEEP BECAUSE OF OVERLOAD.</p> <p>STEP 2 - PRESS TEST BUTTON, WATCHES POWER LED STOP AND RED LED FLASHES FOUR TIMES AND BEEP BECAUSE OF OVERLOAD.</p> <p>STEP 3 - PRESS TEST BUTTON, WATCHES POWER LED STOP AND RED LED FLASHES FOUR TIMES AND BEEP BECAUSE OF OVERLOAD.</p> <p>STEP 4 - PRESS TEST BUTTON, WATCHES POWER LED STOP AND RED LED FLASHES FOUR TIMES AND BEEP BECAUSE OF OVERLOAD.</p> <p>STEP 5 - PRESS TEST BUTTON, WATCHES POWER LED STOP AND RED LED FLASHES FOUR TIMES AND BEEP BECAUSE OF OVERLOAD.</p> <p>STEP 6 - PRESS TEST BUTTON, WATCHES POWER LED STOP AND RED LED FLASHES FOUR TIMES AND BEEP BECAUSE OF OVERLOAD.</p> <p>STEP 7 - PRESS TEST BUTTON, WATCHES POWER LED STOP AND RED LED FLASHES FOUR TIMES AND BEEP BECAUSE OF OVERLOAD.</p> <p>STEP 8 - PRESS TEST BUTTON, WATCHES POWER LED STOP AND RED LED FLASHES FOUR TIMES AND BEEP BECAUSE OF OVERLOAD.</p> <p>STEP 9 - PRESS TEST BUTTON, WATCHES POWER LED STOP AND RED LED FLASHES FOUR TIMES AND BEEP BECAUSE OF OVERLOAD.</p> <p>STEP 10 - PRESS TEST BUTTON, WATCHES POWER LED STOP AND RED LED FLASHES FOUR TIMES AND BEEP BECAUSE OF OVERLOAD.</p> <p>STEP 11 - PRESS TEST BUTTON, WATCHES POWER LED STOP AND RED LED FLASHES FOUR TIMES AND BEEP BECAUSE OF OVERLOAD.</p> <p>STEP 12 - PRESS TEST BUTTON, WATCHES POWER LED STOP AND RED LED FLASHES FOUR TIMES AND BEEP BECAUSE OF OVERLOAD.</p> <p>STEP 13 - PRESS TEST BUTTON, WATCHES POWER LED STOP AND RED LED FLASHES FOUR TIMES AND BEEP BECAUSE OF OVERLOAD.</p> <p>STEP 14 - PRESS TEST BUTTON, WATCHES POWER LED STOP AND RED LED FLASHES FOUR TIMES AND BEEP BECAUSE OF OVERLOAD.</p> <p>STEP 15 - PRESS TEST BUTTON, WATCHES POWER LED STOP AND RED LED FLASHES FOUR TIMES AND BEEP BECAUSE OF OVERLOAD.</p> <p>STEP 16 - PRESS TEST BUTTON, WATCHES POWER LED STOP AND RED LED FLASHES FOUR TIMES AND BEEP BECAUSE OF OVERLOAD.</p> <p>STEP 17 - PRESS TEST BUTTON, WATCHES POWER LED STOP AND RED LED FLASHES FOUR TIMES AND BEEP BECAUSE OF OVERLOAD.</p> <p>STEP 18 - PRESS TEST BUTTON, WATCHES POWER LED STOP AND RED LED FLASHES FOUR TIMES AND BEEP BECAUSE OF OVERLOAD.</p> <p>STEP 19 - PRESS TEST BUTTON, WATCHES POWER LED STOP AND RED LED FLASHES FOUR TIMES AND BEEP BECAUSE OF OVERLOAD.</p> <p>STEP 20 - PRESS TEST BUTTON, WATCHES POWER LED STOP AND RED LED FLASHES FOUR TIMES AND BEEP BECAUSE OF OVERLOAD.</p>	<p>INSTRUCCIONES DE PRUEBA DE GP/GP - PRUEBA ANTES DE CADA USO</p> <p>ESTADO DE FUNCIONAMIENTO NORMAL - DETENER EN CASO DE SOBRECARGA ES BUENO Y NO DEBE CONSIDERARSE UN "SOBRECARGA"</p> <p>PAUSA 1 - PRESIONAR BOTON DE PRUEBA, VERIFICAR QUE EL LED ROJO PARPADEE CUATRO VECES Y EL LED VERDE SE APAGUE.</p> <p>PAUSA 2 - PRESIONAR BOTON DE PRUEBA, VERIFICAR QUE EL LED ROJO PARPADEE CUATRO VECES Y EL LED VERDE SE APAGUE.</p> <p>PAUSA 3 - PRESIONAR BOTON DE PRUEBA, VERIFICAR QUE EL LED ROJO PARPADEE CUATRO VECES Y EL LED VERDE SE APAGUE.</p> <p>PAUSA 4 - PRESIONAR BOTON DE PRUEBA, VERIFICAR QUE EL LED ROJO PARPADEE CUATRO VECES Y EL LED VERDE SE APAGUE.</p> <p>PAUSA 5 - PRESIONAR BOTON DE PRUEBA, VERIFICAR QUE EL LED ROJO PARPADEE CUATRO VECES Y EL LED VERDE SE APAGUE.</p> <p>PAUSA 6 - PRESIONAR BOTON DE PRUEBA, VERIFICAR QUE EL LED ROJO PARPADEE CUATRO VECES Y EL LED VERDE SE APAGUE.</p> <p>PAUSA 7 - PRESIONAR BOTON DE PRUEBA, VERIFICAR QUE EL LED ROJO PARPADEE CUATRO VECES Y EL LED VERDE SE APAGUE.</p> <p>PAUSA 8 - PRESIONAR BOTON DE PRUEBA, VERIFICAR QUE EL LED ROJO PARPADEE CUATRO VECES Y EL LED VERDE SE APAGUE.</p> <p>PAUSA 9 - PRESIONAR BOTON DE PRUEBA, VERIFICAR QUE EL LED ROJO PARPADEE CUATRO VECES Y EL LED VERDE SE APAGUE.</p> <p>PAUSA 10 - PRESIONAR BOTON DE PRUEBA, VERIFICAR QUE EL LED ROJO PARPADEE CUATRO VECES Y EL LED VERDE SE APAGUE.</p> <p>PAUSA 11 - PRESIONAR BOTON DE PRUEBA, VERIFICAR QUE EL LED ROJO PARPADEE CUATRO VECES Y EL LED VERDE SE APAGUE.</p> <p>PAUSA 12 - PRESIONAR BOTON DE PRUEBA, VERIFICAR QUE EL LED ROJO PARPADEE CUATRO VECES Y EL LED VERDE SE APAGUE.</p> <p>PAUSA 13 - PRESIONAR BOTON DE PRUEBA, VERIFICAR QUE EL LED ROJO PARPADEE CUATRO VECES Y EL LED VERDE SE APAGUE.</p> <p>PAUSA 14 - PRESIONAR BOTON DE PRUEBA, VERIFICAR QUE EL LED ROJO PARPADEE CUATRO VECES Y EL LED VERDE SE APAGUE.</p> <p>PAUSA 15 - PRESIONAR BOTON DE PRUEBA, VERIFICAR QUE EL LED ROJO PARPADEE CUATRO VECES Y EL LED VERDE SE APAGUE.</p> <p>PAUSA 16 - PRESIONAR BOTON DE PRUEBA, VERIFICAR QUE EL LED ROJO PARPADEE CUATRO VECES Y EL LED VERDE SE APAGUE.</p> <p>PAUSA 17 - PRESIONAR BOTON DE PRUEBA, VERIFICAR QUE EL LED ROJO PARPADEE CUATRO VECES Y EL LED VERDE SE APAGUE.</p> <p>PAUSA 18 - PRESIONAR BOTON DE PRUEBA, VERIFICAR QUE EL LED ROJO PARPADEE CUATRO VECES Y EL LED VERDE SE APAGUE.</p> <p>PAUSA 19 - PRESIONAR BOTON DE PRUEBA, VERIFICAR QUE EL LED ROJO PARPADEE CUATRO VECES Y EL LED VERDE SE APAGUE.</p> <p>PAUSA 20 - PRESIONAR BOTON DE PRUEBA, VERIFICAR QUE EL LED ROJO PARPADEE CUATRO VECES Y EL LED VERDE SE APAGUE.</p>	<p>INSTRUCTIONS D'ESSAI DE GP/GP - METTRE A L'EPREUVE AVANT CHAQUE UTILISATION</p> <p>ETAT DE FONCTIONNEMENT NORMAL - LE DETOURNEMENT EN CAS DE SURCHARGE EST UN PHENOMENE NORMAL</p> <p>ETAPES 1 - APPUYER SUR LE BOUTON DE TEST, VÉRIFIER QUE LE LED ROUGE CLIGNOTE QUATRE FOIS ET QUE LE LED VERDE S'ÉTEINT.</p> <p>ETAPES 2 - APPUYER SUR LE BOUTON DE TEST, VÉRIFIER QUE LE LED ROUGE CLIGNOTE QUATRE FOIS ET QUE LE LED VERDE S'ÉTEINT.</p> <p>ETAPES 3 - APPUYER SUR LE BOUTON DE TEST, VÉRIFIER QUE LE LED ROUGE CLIGNOTE QUATRE FOIS ET QUE LE LED VERDE S'ÉTEINT.</p> <p>ETAPES 4 - APPUYER SUR LE BOUTON DE TEST, VÉRIFIER QUE LE LED ROUGE CLIGNOTE QUATRE FOIS ET QUE LE LED VERDE S'ÉTEINT.</p> <p>ETAPES 5 - APPUYER SUR LE BOUTON DE TEST, VÉRIFIER QUE LE LED ROUGE CLIGNOTE QUATRE FOIS ET QUE LE LED VERDE S'ÉTEINT.</p> <p>ETAPES 6 - APPUYER SUR LE BOUTON DE TEST, VÉRIFIER QUE LE LED ROUGE CLIGNOTE QUATRE FOIS ET QUE LE LED VERDE S'ÉTEINT.</p> <p>ETAPES 7 - APPUYER SUR LE BOUTON DE TEST, VÉRIFIER QUE LE LED ROUGE CLIGNOTE QUATRE FOIS ET QUE LE LED VERDE S'ÉTEINT.</p> <p>ETAPES 8 - APPUYER SUR LE BOUTON DE TEST, VÉRIFIER QUE LE LED ROUGE CLIGNOTE QUATRE FOIS ET QUE LE LED VERDE S'ÉTEINT.</p> <p>ETAPES 9 - APPUYER SUR LE BOUTON DE TEST, VÉRIFIER QUE LE LED ROUGE CLIGNOTE QUATRE FOIS ET QUE LE LED VERDE S'ÉTEINT.</p> <p>ETAPES 10 - APPUYER SUR LE BOUTON DE TEST, VÉRIFIER QUE LE LED ROUGE CLIGNOTE QUATRE FOIS ET QUE LE LED VERDE S'ÉTEINT.</p> <p>ETAPES 11 - APPUYER SUR LE BOUTON DE TEST, VÉRIFIER QUE LE LED ROUGE CLIGNOTE QUATRE FOIS ET QUE LE LED VERDE S'ÉTEINT.</p> <p>ETAPES 12 - APPUYER SUR LE BOUTON DE TEST, VÉRIFIER QUE LE LED ROUGE CLIGNOTE QUATRE FOIS ET QUE LE LED VERDE S'ÉTEINT.</p> <p>ETAPES 13 - APPUYER SUR LE BOUTON DE TEST, VÉRIFIER QUE LE LED ROUGE CLIGNOTE QUATRE FOIS ET QUE LE LED VERDE S'ÉTEINT.</p> <p>ETAPES 14 - APPUYER SUR LE BOUTON DE TEST, VÉRIFIER QUE LE LED ROUGE CLIGNOTE QUATRE FOIS ET QUE LE LED VERDE S'ÉTEINT.</p> <p>ETAPES 15 - APPUYER SUR LE BOUTON DE TEST, VÉRIFIER QUE LE LED ROUGE CLIGNOTE QUATRE FOIS ET QUE LE LED VERDE S'ÉTEINT.</p> <p>ETAPES 16 - APPUYER SUR LE BOUTON DE TEST, VÉRIFIER QUE LE LED ROUGE CLIGNOTE QUATRE FOIS ET QUE LE LED VERDE S'ÉTEINT.</p> <p>ETAPES 17 - APPUYER SUR LE BOUTON DE TEST, VÉRIFIER QUE LE LED ROUGE CLIGNOTE QUATRE FOIS ET QUE LE LED VERDE S'ÉTEINT.</p> <p>ETAPES 18 - APPUYER SUR LE BOUTON DE TEST, VÉRIFIER QUE LE LED ROUGE CLIGNOTE QUATRE FOIS ET QUE LE LED VERDE S'ÉTEINT.</p> <p>ETAPES 19 - APPUYER SUR LE BOUTON DE TEST, VÉRIFIER QUE LE LED ROUGE CLIGNOTE QUATRE FOIS ET QUE LE LED VERDE S'ÉTEINT.</p> <p>ETAPES 20 - APPUYER SUR LE BOUTON DE TEST, VÉRIFIER QUE LE LED ROUGE CLIGNOTE QUATRE FOIS ET QUE LE LED VERDE S'ÉTEINT.</p>
---	--	---	--	--



<p>⚠ DANGER</p> <p>Using a generator outdoors CAN KILL! ONLY IN WETTED, Overhead overhead, outdoor activities. They poses you cannot see or smell.</p>	<p>⚠ DANGER</p> <p>NEVER use inside a home or garage. NEVER if doors and windows are open.</p>	<p>⚠ DANGER</p> <p>Only use OUTSIDE and far away from windows, doors, and vents.</p>	<p>⚠ DANGER</p> <p>Correct connection of generator to a building's electrical system can allow electrical current from the generator to flow into utility lines. This may result in electrocution of utility workers, fire or explosion. Connections to a building's electrical system must be made by a qualified electrician and comply with all applicable local and national codes.</p>
--	--	---	---

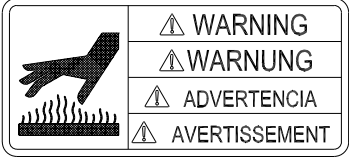
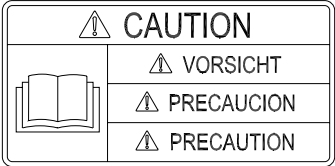

3.6 Safety and Operating Labels

Wacker machines use international pictorial labels where needed. These labels are described below:

Label	Meaning
	<p>WARNING! Hot surface!</p>
	<p>CAUTION! Read and understand the supplied Operator's Manuals before operating this machine. Failure to do so increases the risk of injury to yourself or others.</p>
	<p>CAUTION! Lifting point.</p>
	<p>Choke lever</p>
	<p>Electrical ground</p>

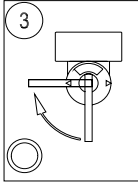
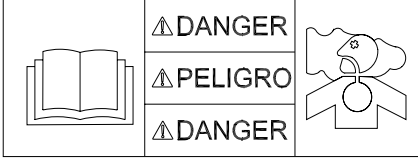
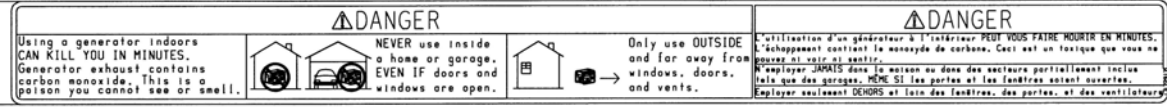
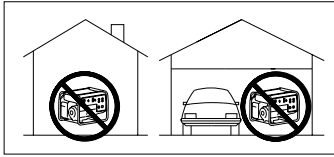
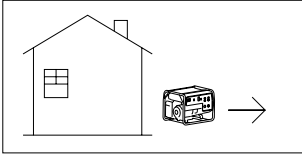
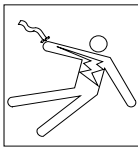
Label	Meaning
	<p>Press circuit breaker switch to OFF position.</p>
	<p>Check the fuel level.</p>
	<p>Open the fuel flow valve.</p>
	<p>Press engine switch to ON position.</p> <p>GPS - Press ignition switch. GP - Pull the rewind starter.</p>
	<p>Press circuit breaker switch to ON position.</p>
	<p>Press engine switch to OFF position.</p>

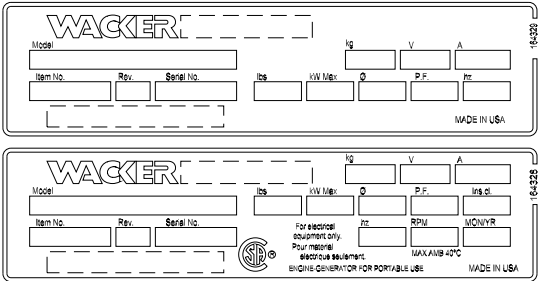
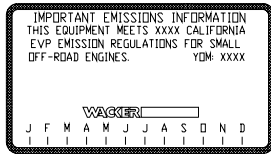
Label	Meaning
	<p>Close the fuel flow valve.</p>
	<p>DANGER! Asphyxiation hazard. Read the Operator's Manual for instructions.</p>
	
<p>Using a generator indoors CAN KILL YOU IN MINUTES. Generator exhaust contains carbon monoxide. This is a poison you cannot see or smell.</p>	<p>Using a generator indoors CAN KILL YOU IN MINUTES. Generator exhaust contains carbon monoxide. This is a poison you cannot see or smell.</p>
	<p>NEVER use inside a home or garage, EVEN IF doors and windows are open.</p>
	<p>Only use OUTSIDE and far away from windows, doors, and vents.</p>
	<p>WARNING! To reduce the risk of electrical shock, read the operator's manual. Improper connection of the generator to a building's electrical system can allow electrical current from the generator to backfeed into utility lines. This may result in electrocution of utility workers, fire or explosion. Connections to a building's electrical system must be made by a qualified electrician and comply with all applicable laws and electrical codes.</p>

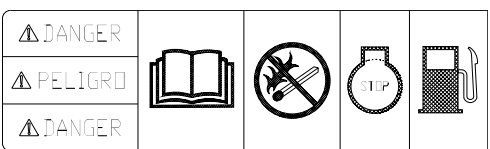
Label	Meaning
	<p>A nameplate listing the model number, item number, revision number, and serial number is attached to each unit. Please record the information found on this plate so it will be available should the nameplate become lost or damaged. When ordering parts or requesting service information, you will always be asked to specify the model number, item number, revision number, and serial number of the unit.</p>
	<p>Important Emissions Information This equipment meets California EVP emission regulations for small off-road engines.</p>
	<p>This machine may be covered by one or more patents.</p>
	<p>DANGER! No sparks, flames or burning objects near machine. Shut off the engine before refueling. Read the operator's manual for machine information.</p>

Label	Meaning
 <p>Normal operating state - sensing device green LED is "ON" and circuit breaker is at "ON" position.</p> <p>STEP 1: Press "TEST" button. Green LED should go "OUT" and red LED should come "ON" and circuit breaker should trigger to "OFF" position.</p> <p>STEP 2: If sensing device LED or breaker does not trip or change state, "DO NOT USE". Consult an electrician for assistance.</p> <p>STEP 3: Press "RESET" button. Red LED should turn "OFF" and green LED should turn "ON".</p> <p>STEP 4: Manually reset (switch) circuit breaker to "ON" position to restore circuit power.</p>	<p>GFCI TEST INSTRUCTIONS - TEST BEFORE EACH USE</p> <p>ESTADO DE FUNCIONAMIENTO NORMAL -- SUSPENDIDO DE PROTECCION ALTA VOLTAJE ESTA ALUMBRADO Y EL INTERRUPTOR DE CIRCUITO ESTA EN LA POSICION "ON"</p> <p>PRUEBA 1: PRESIONE EL BOTON DE "PRUEBA". EL LED VERDE DEBE APAGARSE Y EL INTERRUPTOR DE CIRCUITO DEBE PASAR A LA POSICION "OFF". EL LED ROJO DEBE ENCENDERSE Y EL INTERRUPTOR DE CIRCUITO DEBE PASAR A LA POSICION "ON".</p> <p>PRUEBA 2: SI EL INTERRUPTOR DE CIRCUITO O EL LED VERDE NO CAMBIA SU ESTADO, NO SE DEBE USAR EL EQUIPO. CONSULTAR CON UN ELECTRICISTA PARA OBTENER AYUDA.</p> <p>PRUEBA 3: PRESIONE EL BOTON DE "RESET". EL LED ROJO DEBE APAGARSE Y EL LED VERDE DEBE ENCENDERSE.</p> <p>PRUEBA 4: REAJUSTE MANUALMENTE EL INTERRUPTOR DE CIRCUITO A LA POSICION "ON" PARA RESTAURAR LA ENERGIA DEL CIRCUITO.</p>
<p>GFCI TEST INSTRUCTIONS - TEST BEFORE EACH USE</p>	
<p>Normal operating state - sensing device green LED is "ON" and circuit breaker is at "ON" position.</p>	
<p>Step 1: Press "TEST" button. Green LED should go "OUT" and red LED should come "ON" and circuit breaker should trigger to "OFF" position.</p>	
<p>Step 2: If sensing device LED or breaker does not trip or change state, "DO NOT USE". Consult an electrician for assistance.</p>	
<p>Step 3: Press "RESET" button. Red LED should turn "OFF" and green LED should turn "ON".</p>	
<p>Step 4: Manually reset (switch) circuit breaker to "ON" position to restore circuit power.</p>	

4. Technical Data

4.1 Generator

Item No.		GP 5600A 0620091	GP 5600A 0620092	GPS 5600A 0620093
Generator				
Maximum Output	W	5600		
Continuous Output	W	5000		
Type		Dual voltage, single phase, Auto voltage regulator system		
AC Voltages Available	volts phase	120 / 240 1ø		
Frequency	Hz	60		
Power Factor		1.0		
AC receptacles:				
125V duplex	amp	20		
125V duplex	amp	20		
125V twist-lock	amp	30		
125V/250V twist-lock	amp	30		
Main Circuit Breaker	amp	2-pole, 23 amp each pole		
L x W x H	mm (in.)	685 x 530 x 520 (27 x 21 x 20.5)	1005 x 685 x 660 (39.5 x 27 x 26)	870 x 530 x 520 (34.3 x 21 x 20.5)
Weight (dry)	Kg (lbs.)	84 (186)	94 (208)	91 (201)

Item No.		GP 5600A CAN 0620094	GP 5600A CAN 0620095	GPS 5600A CAN 0620096
Generator				
Maximum Output	W	5600		
Continuous Output	W	5000		
Type		Dual voltage, single phase, Auto voltage regulator system		
AC Voltages Available	volts phase	120 / 240 1 ϕ		
Frequency	Hz	60		
Power Factor		1.0		
AC receptacles:				
125V duplex	amp	20		
125V duplex	amp	20		
125V twist-lock	amp	30		
125V/250V twist-lock	amp	30		
Main Circuit Breaker	amp	2-pole, 23 amp each pole		
L x W x H	mm (in.)	685 x 530 x 520 (27 x 21 x 20.5)	1005 x 685 x 660 (39.5 x 27 x 26)	870 x 530 x 520 (34.3 x 21 x 20.5)
Weight (dry)	Kg (lbs.)	84 (186)	94 (208)	91 (201)

4.2 Engine

Item No.	GP 5600A	GP 5600A CAN	GPS 5600A	GPS 5600A CAN
	0620091 0620092	0620094 0620095	0620093	0620096
Engine				
Engine Type	Single cylinder, 4-cycle, air-cooled, gasoline engine			
Engine Make	Honda			
Engine Model	GX 340 K1			
Rated Power	kW (Hp)	8.2 (11)		
Spark Plug	BPR6ES / W20EPR-U			
Electrode Gap	mm (in.)	0.7 - 0.8 (0.028 - 0.031)		
Operating Speed (Max.)	rpm	3600		
Auto Idle VAC	high idle low idle	119 90		
Air Cleaner	type	Dry type with oil-wetted foam pre-cleaner		
Battery	type V/ capacity Size (in.)	N/A	Y50-N18L-A 12V - 20 Amp-hour 8- ¹ / ₈ x 3- ⁹ / ₁₆ x 6- ⁷ / ₁₆	
Engine Lubrication	oil grade	SAE 10W30 service class SF, SE, SD or SC		
Engine Oil Capacity	l (qts.)	1.1 (1.2)		
Fuel	type	Regular unleaded gasoline		
Fuel Tank Capacity	l (gal.)	19.5 (5.2)		
Fuel Consumption	l (qts.)/ hr.	3.2 (3.4)		
Running Time	hrs.	6		

5. Operation

5.1 Determining Power Requirements

This generator is designed to operate single-phase, 60 Hz appliances running at 120 VAC or 240 VAC. Check the nameplate or label provided on tools and appliances to make sure their power requirements match the power output of the generator.

Some appliances and tools require a surge of current when starting. This means that the amount of power needed to initially start the equipment is larger than the power required to keep it running. The generator must be capable of supplying this “surge” current. Other types of appliances require more power than is actually stated on their nameplate.

The information in “Approximate Starting Power Requirements” is offered only as a general guideline to help you in determining power requirements for different types of equipment. Check with your nearest Wacker Dealer, or contact the manufacturer or dealer of the tool or appliance, with questions regarding its power requirements.

NOTICE: If a tool or appliance does not reach full speed within a few seconds when switched on, turn it off immediately to avoid damage.

Approximate Starting Power Requirements

- Incandescent lights and appliances such as irons and hot plates, which use a resistive-type heating element, require the same wattage to start and run as is stated on their nameplates.
- Fluorescent and mercury lamps require 1.2–2 times their stated wattage to start.
- Electrical motors and many types of electrical tools often require a large starting current. The amount of starting current depends on the type of motor and its use.
- Most electrical tools require 1.2–3 times their stated wattage for starting.
- Loads such as submersible pumps and air compressors require a very large force to start. They need as much as 3–5 times the wattage stated on the nameplate in order to start.

If the wattage is not given for a particular tool or appliance, it can be calculated by multiplying its voltage and amperage requirements:

Single Phase: VOLTS x AMPS = WATTS

5.2 Outdoor Installation

Place the generator in an area where it will not be exposed to rain, snow, or direct sunlight. Make sure it is positioned on firm, level ground, so it will not slide or shift. Position the engine exhaust away from areas where people may be present.

If operating the generator inside a tunnel or deep trench, make sure there is adequate ventilation. Precautions similar to those required when operating indoors may be necessary.

The surrounding area must be free from water and moisture. All components must be protected from excessive moisture.

5.3 Indoor Installation

If the generator must be installed indoors, adequate ventilation or exhaust hoses must be provided. When venting exhaust fumes, make sure the exhaust piping is large enough to prevent excessive back pressure to the engine. Back pressure reduces engine efficiency and may cause the engine to overheat.



Exhaust gas from the engine contains poisonous carbon monoxide gas; exposure to carbon monoxide can cause loss of consciousness and may lead to death. Never run the generator indoors or in an enclosed area unless adequate ventilation, through such items as exhaust hoses or fans, is provided.

When installed indoors, steps to prevent fire and explosion such as providing a good, earthen ground, removing all flammable materials near the generator, and using only electrical cables in good condition, must be observed. See *Operating Safety*.

5.4 Recommended Battery (GPS only)

This generator is shipped without a battery. The recommended battery to be used is:

Battery Type	50-N18L-A
Voltage	12 V
Capacity	20 A/h
L x W x H	206 x 90 x 164 mm (8-1/8 x 3-9/16 x 6-7/16 in.)

5.5 Battery Tray Installation (GPS only)

- 5.5.1 Align the holes found in the battery tray (**a**) to the holes on the frame cross-member
- 5.5.2 Insert M8 x 14 screws (**b**) through the tray then through the holes of the cross-member.
- 5.5.3 Insert the nuts (**c**) onto the screws and tighten. Torque nuts to 18.75 Nm. (13.5 ft.lbs).
- 5.5.4 Align the holes in the battery tube (**d**) to the holes in front of the battery tray.
- 5.5.5 Insert M8 x 35 screws (**e**) through the battery tray then through the tube.
- 5.5.6 Insert the nuts (**f**) onto the screws and tighten. Torque nuts to 18.75 Nm. (13.5 ft.lbs).
- 5.5.7 Insert the tube clamps (**g**) onto the upper frame tube and align the holes to the holes of the battery tube.
- 5.5.8 Insert M8 x 35 screws (**h**) through the battery tube then through the tube clamps.
- 5.5.9 Insert the nuts (**j**) onto the bolts and tighten. Torque nuts to 18.75 Nm. (13.5 ft.lbs).
- 5.5.10 Slide the J-bolt (**k**) through the holes found in the battery holder (**l**).
- 5.5.11 Insert the rounded end of the J-bolt (**k**) into the slot of the battery tray and insert the tip of the J-bolt through the hole.

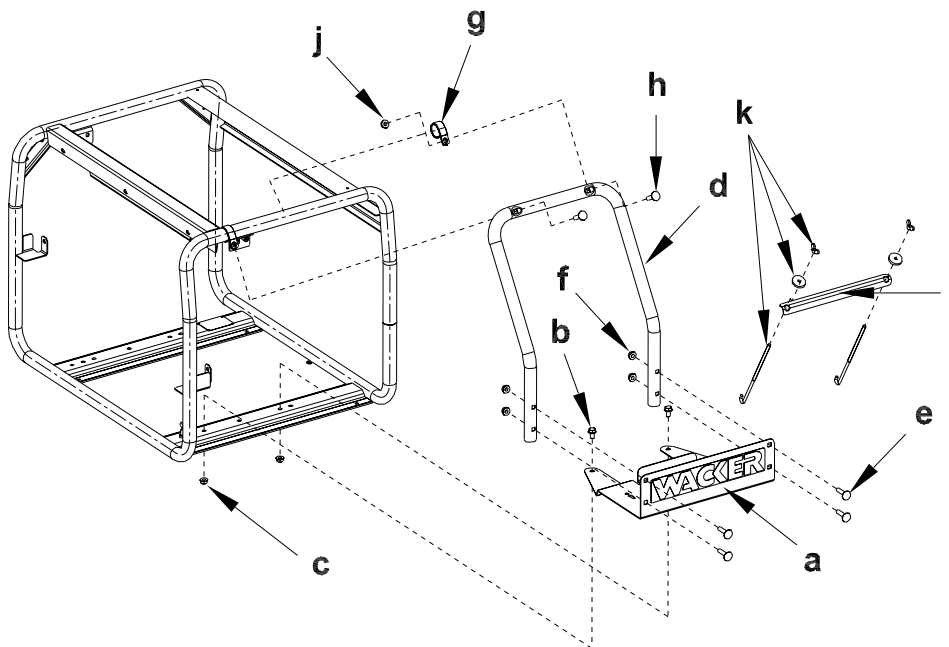

5.6 Wheel Kit

The wheel kit (Part No. 0161308) is a standard item on Item Number 0620012, 0620015, 0620043 and 0620046 only. It is available as an option on all other models.

- 5.6.1 Hoist the generator, and align the axle **(c)** with the lower cross-member of frame.
- 5.6.2 Insert the axle brackets **(k)** over the axle and align the holes found in the axle bracket to the holes of the cross-member. Ensure that the brackets extend under the tube of the frame.
- 5.6.3 Insert M6 x 16 screws **(l)** through the outer holes on the cross-member, then through the holes of the axle bracket.
- 5.6.4 Insert M6 nuts **(m)** onto the screws and tighten. Torque to 7.5 Nm (5.25 ft.lbs.).
- 5.6.5 Assemble the washers **(g)** next to the rings **(h)**, then add the wheels **(d)**.
- 5.6.6 Add the washers **(g)** next to the wheels, then insert the pins **(f)** into the holes of the axle and separate the legs of the pins.
- 5.6.7 Align the holes found in the leg bracket **(b)** to the holes of the lower cross-member.
- 5.6.8 Insert M6 x 16 screws **(l)** through the outer holes on the cross-member, then through the holes of the leg bracket.
- 5.6.9 Insert M6 nuts **(n)** onto the screws and tighten. Torque to 7.5 Nm (5.25 ft.lbs.).
- 5.6.10 Insert M8 x 30 screw **(o)** through the hole in the leg bracket and through the hole in cross-member.
- 5.6.11 Insert M8 nut **(p)** onto the screw and tighten. Torque to 18.75 Nm (13.5 ft.lbs.).
- 5.6.12 Align the holes in the rubber foot mounts **(e)** to the holes of the leg bracket.
- 5.6.13 Insert M6 x 20 screws **(m)** through the leg bracket, then through the holes of the rubber foot mounts.
- 5.6.14 Insert the nuts **(n)** onto the screws and tighten. Torque to 7.5 Nm (5.25 ft.lbs.).
- 5.6.15 Align the holes found in the handles **(a, j)** to the holes of the brackets **(1)** on the frame.
- 5.6.16 Insert M6 x 16 screws **(l)** through the handles, then through the brackets on the frame.
- 5.6.17 Insert nuts **(m)** onto the screws and tighten. Torque to 7.5 Nm (5.25 ft.lbs.).

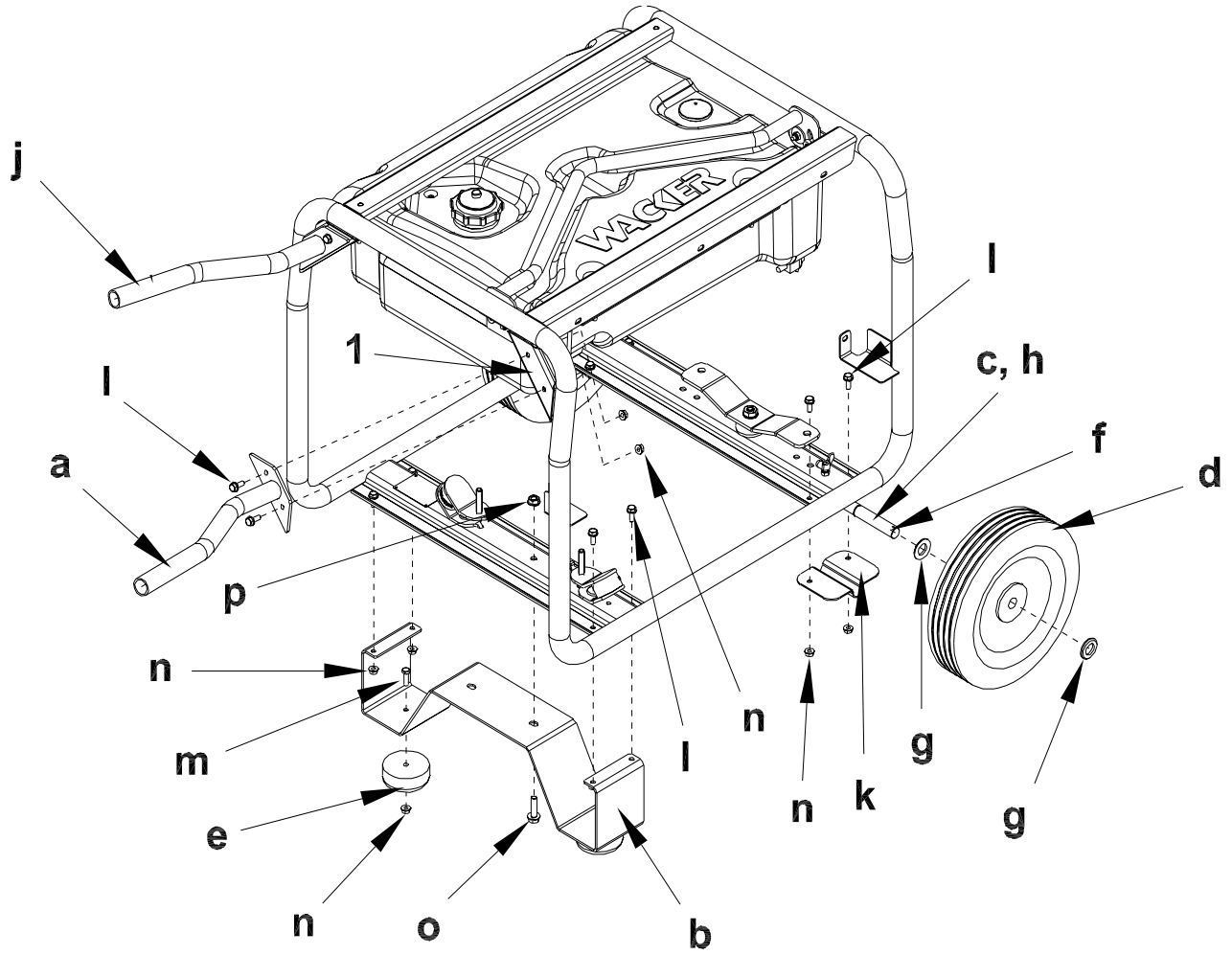

5.7 Generator Derating

All generators are subject to derating for altitude and temperature. Internal combustion engines, unless modified, run less efficiently at higher altitudes due to the reduction of air pressure. This translates into a lack of power and thus reduction in generator output. Temperature affects both engine and generator performance. As temperature increases, an engine will run less efficiently and more resistance will be found in electrical components. Therefore, as the temperature increases, the output of the generator decreases. Altitude also affects the cooling capacity of air—the higher the altitude the less dense the air is and thus the lower its ability to transfer heat.

For every increase in altitude of 500 m (1650 ft.) above 1000 m (3300 ft.), the output of the generator will be reduced by 3%. For every increase of 5° C (9° F) in ambient temperature above 40° C (104° F), the output of the generator will be reduced by 3%. Use the tables shown for altitude and temperature deration factors. It may be necessary to consider both altitude and ambient temperature deration factors to determine true generator output.

Ambient Temp. °C (°F)	Derate	Factor
45 (113)	3 %	0.97
50 (122)	6 %	0.94
55 (131)	9 %	0.91
60 (140)	12 %	0.88

Altitude m (ft.)	Derate	Factor
1500 (4900)	3 %	0.97
2000 (6600)	6 %	0.94
2500 (8200)	9 %	0.91
3000 (9900)	12 %	0.88
3500 (11500)	15 %	0.85
4000 (13100)	18 %	0.82

5.8 Grounding the Generator

A ground connection (**a**) is located on the generator frame. For proper operating safety, this ground terminal must be connected to a good ground source. This ground connection must comply with National Electrical Code standards, and state and local regulations.

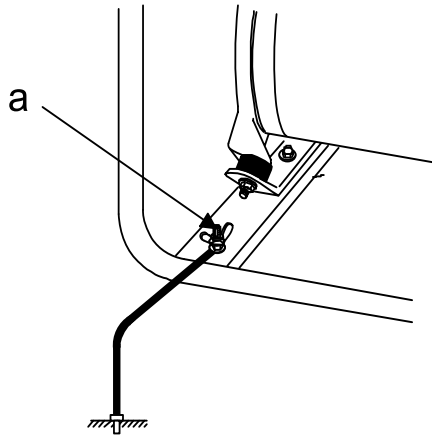

5.9 Operating Heavy Loads

Limit operations requiring the maximum rated output of 5600 W to 20–30 minutes. For continuous operation do not exceed the continuous rated output of 5000 W.

NOTICE: DO NOT exceed the current limit specified on the control panel for any receptacle.

5.10 Use of Extension Cords

When a long extension cord is used to connect an appliance or tool to the generator, a voltage loss occurs—the longer the cord, the greater the voltage loss. This results in less voltage being supplied to the appliance or tool and increases the amount of current draw or reduces performance. A heavier cord with a larger wire size will reduce the voltage loss.



Damaged extension cords can cause electrical shock, resulting in serious injury or death. DO NOT use worn, bare, or frayed cords. Replace damaged cords immediately.

Use the chart below as a guide for selecting proper cable size.

Current (Amps)	Load in Watts		Maximum Cable Length in Feet			
	120V	240V	#10	#12	#14	#16
2.5	300	600	1000.	600	375	250
5	600	1200	500	300	200	125
7.5	900	1800	350	200	125	100
10	1200	2400	250	150	100	-
15	1800	3600	150	100	65	-
20	2400	4800	125	75	50	-

Use only extension cords rated for outdoor use and equipped with a third-wire ground.

NOTICE: Operating equipment at low voltage can cause it to overheat.

5.11 Control Panel

Ref.	Description	Ref.	Description
a	Engine Switch	g	GFCI test button
b	Auto Idle Switch	h	GFCI reset button
c	Twist-lock receptacle - 120V	j	Twist-lock receptacle - 120/240V
d	Main Circuit Breaker	k	Ignition Switch (GPS only)
e	Voltage Selector Switch	m	20A circuit breaker (CAN only)
f	Duplex receptacle - 120V	n	30A circuit breaker (CAN only)

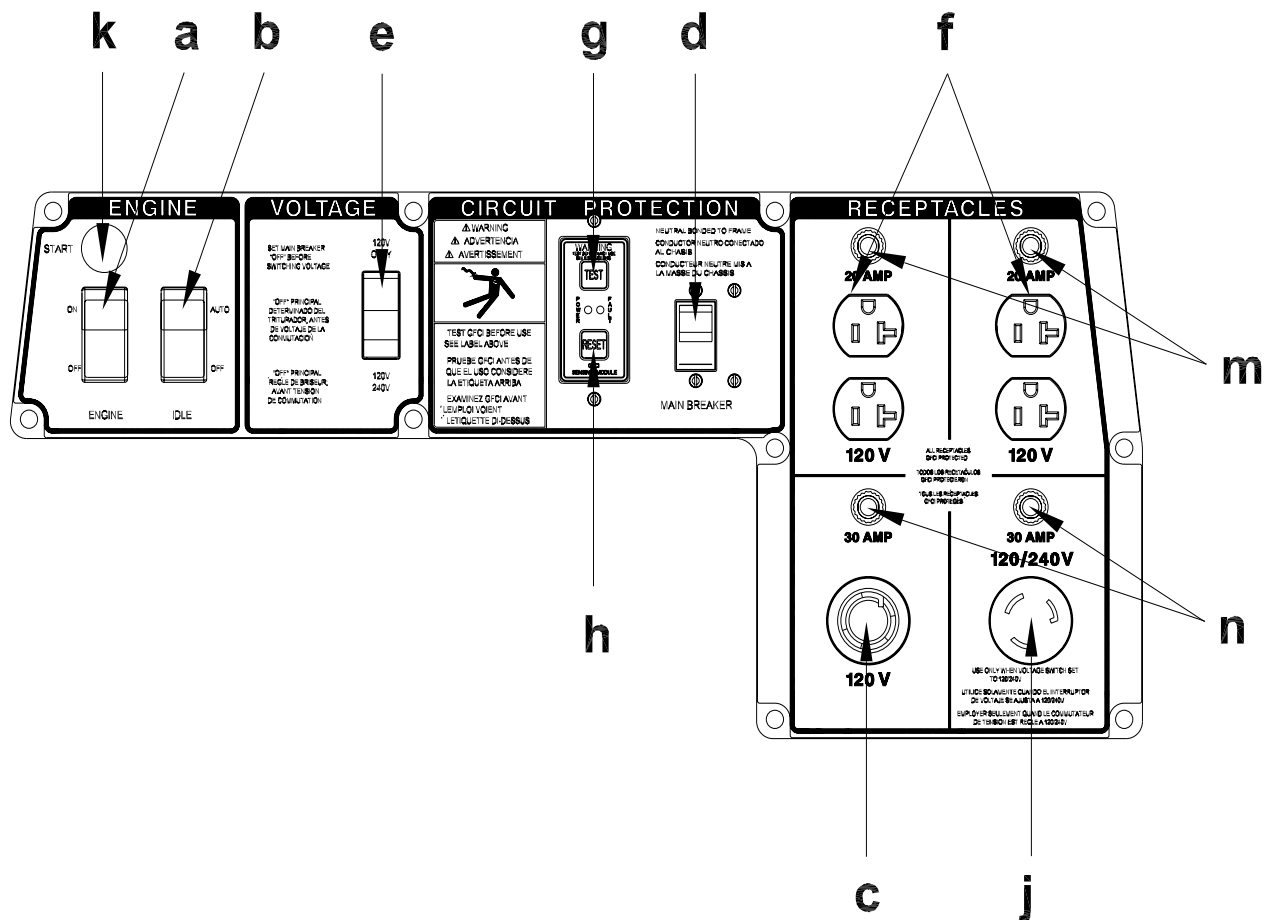

5.12 Ground Fault Circuit Interrupter (GFCI)

The GFCI should be tested for proper operations every time the generator is used.

Normal operating state - sensing device green LED is “ON” and circuit breaker is at “ON” position.

- 5.12.1 Press “TEST” button (g). Green LED should go “OUT” and red LED should come “ON” and circuit breaker should trigger to “OFF” position (d).
- 5.12.2 If sensing device LED or breaker does not trip or change state, “DO NOT USE”. Consult an electrician for assistance.
- 5.12.3 Press “RESET” button (h). Red LED should turn “OFF” and green LED should turn “ON”.
- 5.12.4 Manually reset (switch) circuit breaker to “ON” position to restore circuit power (d).

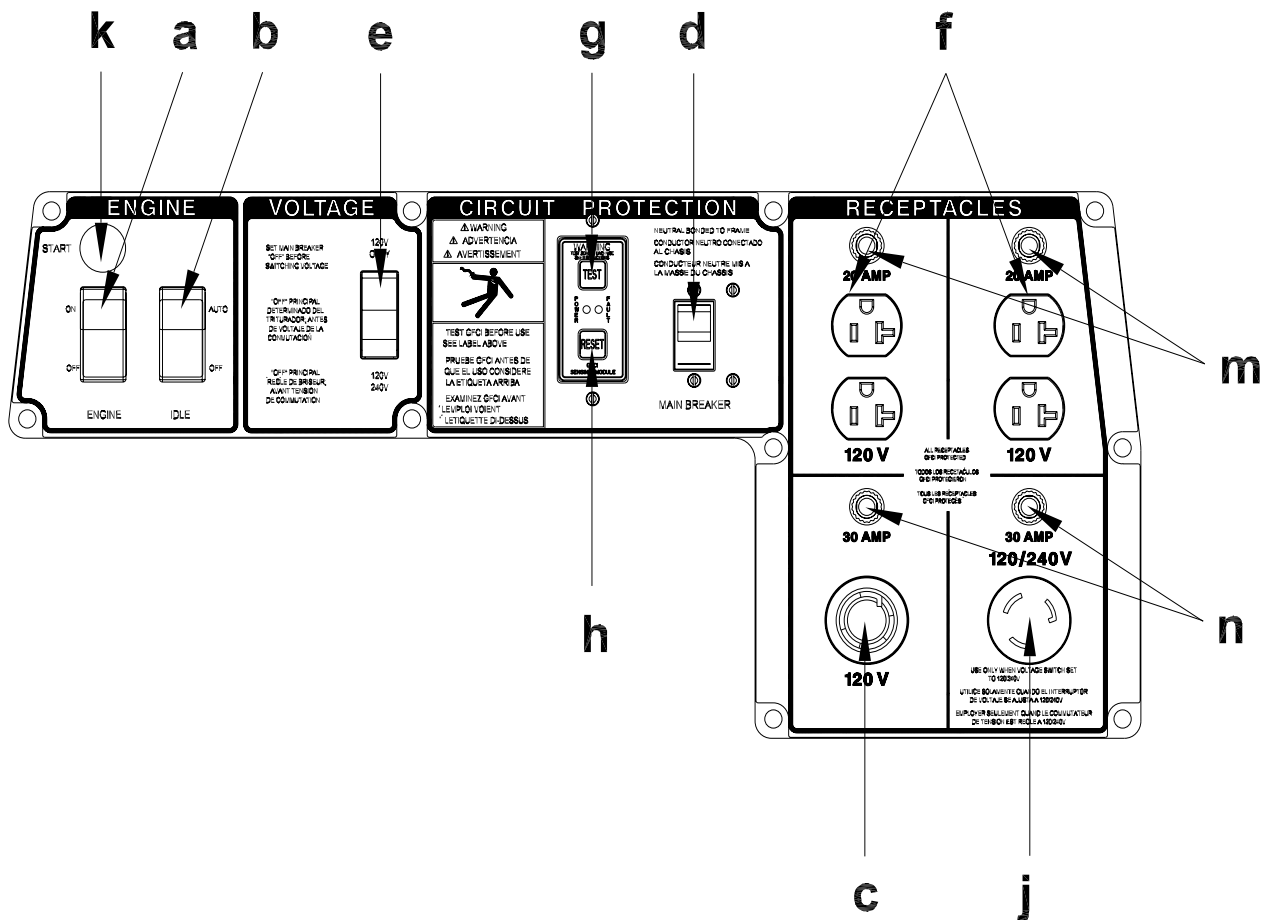

5.13 Twist Lock Receptacles

Twist-lock receptacles (**c, j**) are used at the 120V Amp and 120/240V outlets. These receptacles are protected by the GFCI.

To attach a power cord to a twist-lock receptacle, insert plug into receptacle and turn it clockwise to lock it in place.

5.14 Engine Auto Idle

The auto idle switch (**b**) automatically reduces engine speed approximately 7 seconds after all appliances or tools attached to the generator have been turned off. The engine automatically returns to full speed when a tool or appliance is turned back on.

To turn the auto idle feature on, push the auto idle switch to “AUTO”. The AUTO setting is recommended while the generator is running to minimize fuel consumption. To avoid extended engine warm-up periods, keep switch set to “OFF” when starting the engine and until the engine reaches operating temperature.

5.15 Engine Speed

Generators require a fixed engine speed to maintain the correct voltage. Engine speed is controlled by a governor which automatically adjusts to varying loads on the engine to maintain a constant speed. See *Technical Data*. There is no throttle control. Use the Auto Idle switch on the generator to control engine speed.

5.16 Voltage Selection

The voltage selector switch (**e**) allows the generator to operate in either single (120V) or dual voltage (120/240V) mode.

In single-voltage mode, use only the 120V twist-lock (**c**) and duplex receptacles (**f1**, **f2**). The full rated power of the generator is shared between the three receptacles.

In dual voltage mode both the 120V and 120/240V receptacles are powered; lower watts are available on receptacles (**f1**, **f2**, **c**). The 120/240V twist-lock receptacle (**j**) should be used in dual mode only. To achieve full power in this receptacle it should be used alone.

NOTICE: NEVER switch the voltage selector switch with the main breaker on! This can cause arcing and can damage the generator. Turn all tools and appliances off and place main breaker (**d**) in the OFF position before changing voltage switch position.

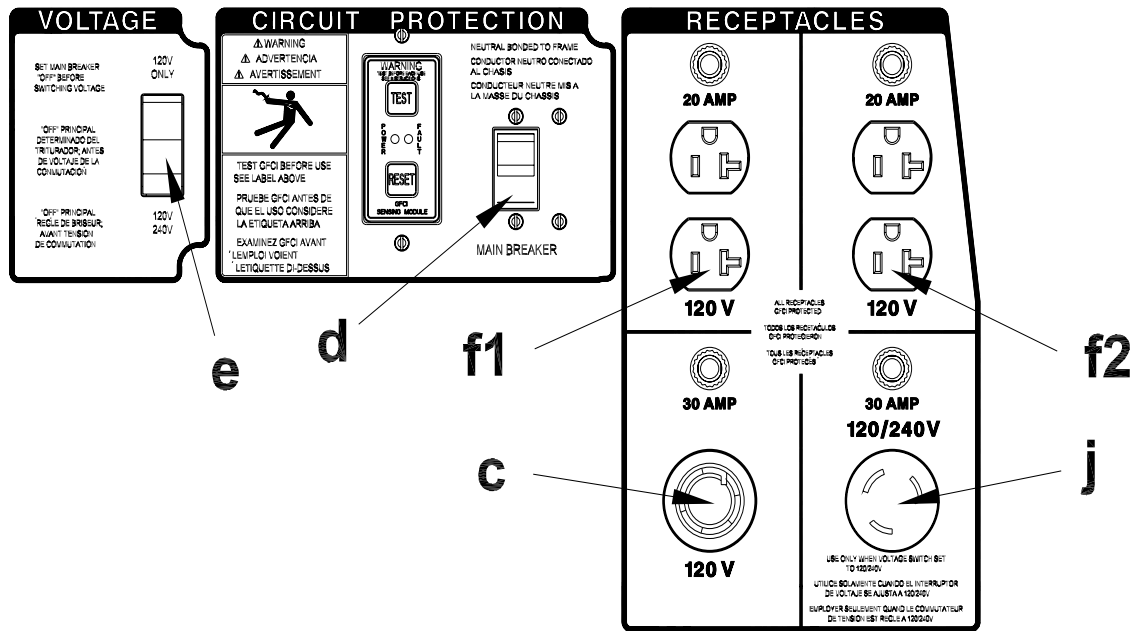

5.17 Before Starting

- 5.17.1 Read and understand the safety and operating labels and instructions at the beginning of this manual.
- 5.17.2 Inspect the generator for any signs of damage which may affect operation or pose a safety hazard.
- 5.17.3 Check:
- oil level in engine
 - fuel level
 - condition of air cleaner
 - tightness of external fasteners
 - condition of fuel lines.
- Note:** *The engine is equipped with an oil alert system. If the oil level in the engine drops too low, the engine will not start.*
- 5.17.4 Fill the fuel tank with fresh, regular, unleaded grade gasoline. DO NOT use an oil/gas mixture. The use of gasohol or any fuel containing more than 10% ethanol is not recommended. Consult the engine owner's manual for complete fuel specifications.

5.18 To Start

Before starting, be sure you read and understand all the safety and operating instructions in this manual.

- 5.18.1 Disconnect all loads from the generator and place the main circuit breaker switch in the OFF position (a2).
- 5.18.2 Set the auto idle switch to "OFF" (c).
- 5.18.3 Open the fuel valve (d1).

Note: If the engine is cold, move the choke lever to the closed position (e2). If the engine is warm, set the choke lever to the open position (e1).

- 5.18.4 On recoil start engines, turn the engine switch to "ON" (b1) and pull the starter rope (f).
- 5.18.5 On electric start engines, press the ignition switch (k) and hold until the engine starts. Release the switch after the engine starts.

NOTICE: DO NOT run the starter motor more than 5 seconds at a time or damage to the starter motor may occur. If the engine fails to start, release the switch and wait 10 seconds to let the starter motor cool before trying again.

Note: If the oil level in the engine is low, the engine will not start. If this happens, check the oil level and add oil as needed.

- 5.18.6 As the engine warms up, move the choke lever to the OPEN position (e1).
- 5.18.7 Allow the engine to warm up for a few minutes before placing the main breaker in the "ON" position (a1) and attaching loads.

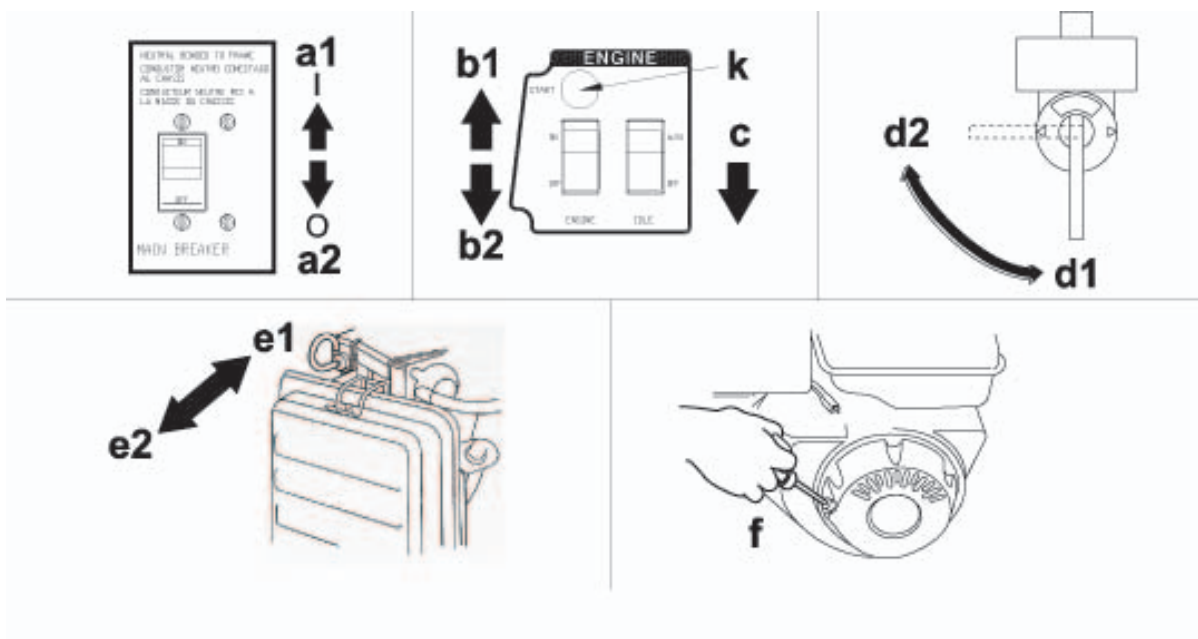

5.19 To Stop

- 5.19.1 Turn off and disconnect all tools and appliances attached to the generator.
- 5.19.2 Place the main circuit breaker in the OFF position **(a2)**.
- 5.19.3 Turn the engine switch to “OFF” **(b2)**.
- 5.19.4 Close the fuel valve **(d2)**.

Note: *To stop the engine quickly in an emergency, turn or press the engine switch to “OFF” **(b2)**.*

6. Maintenance

6.1 Engine Maintenance

The chart below lists basic machine and engine maintenance. Refer to your Wacker Engine Operator’s Manual for additional information on engine maintenance.

6.2 Periodic Maintenance Schedule

	Daily before starting	After first 20 hrs.	Every 50 hrs.	Every 100 hrs.	Every 300 hrs.
Check the fuel level.	■				
Check the engine oil level.	■				
Inspect the air filter. Replace as needed.	■				
Check external hardware.	■				
Clean the air cleaner element.*			■		
Inspect the shockmounts for damage.				■	
Change the engine oil.*		■		■	
Clean the sediment cup or fuel strainer.				■	
Check and clean the spark plug.				■	
Check and adjust the valve clearance.					■
Clean the fuel tank.*					■
Check condition of the fuel line. Replace when necessary.					■

*Service more frequently in dusty conditions.

6.3 Engine Oil

6.3.1 Drain the oil while the engine is still warm.

6.3.2 Remove the oil filler plug **(a)** and the drain plug **(b)** to drain the oil.

Note: *In the interests of environmental protection, place a plastic sheet and a container under the machine to collect any liquid that drains off. Dispose of this liquid in accordance with environmental protection legislation.*

6.3.3 Install the drain plug.

6.3.4 Fill the engine crankcase with the recommended oil up to the level of the plug opening **(c)**. See section *Technical Data* for oil quantity and type.

6.3.5 Install the oil filler plug.

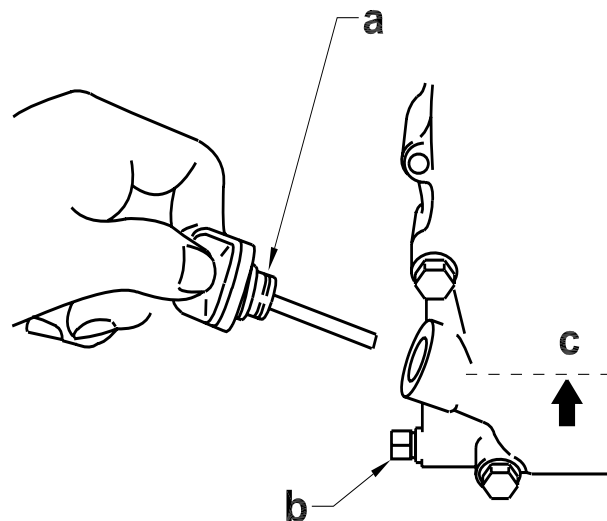

6.4 Servicing Air Cleaner

Service the air cleaner frequently to prevent carburetor malfunction.

NOTICE: NEVER run the engine without the air cleaner. Severe engine damage will occur.



NEVER use gasoline or other types of low flash-point solvents for cleaning the air cleaner. A fire or explosion could result.

To service:

- 6.4.1 Remove the air cleaner cover (**a**). Inspect the element (**b**) for holes or tears. Replace the element if it is damaged.
- 6.4.2 Wash the foam element (**b**) in a solution of mild detergent and warm water. Rinse it thoroughly in clean water. Allow the element to dry thoroughly. Soak the element in clean engine oil and squeeze out excess oil.

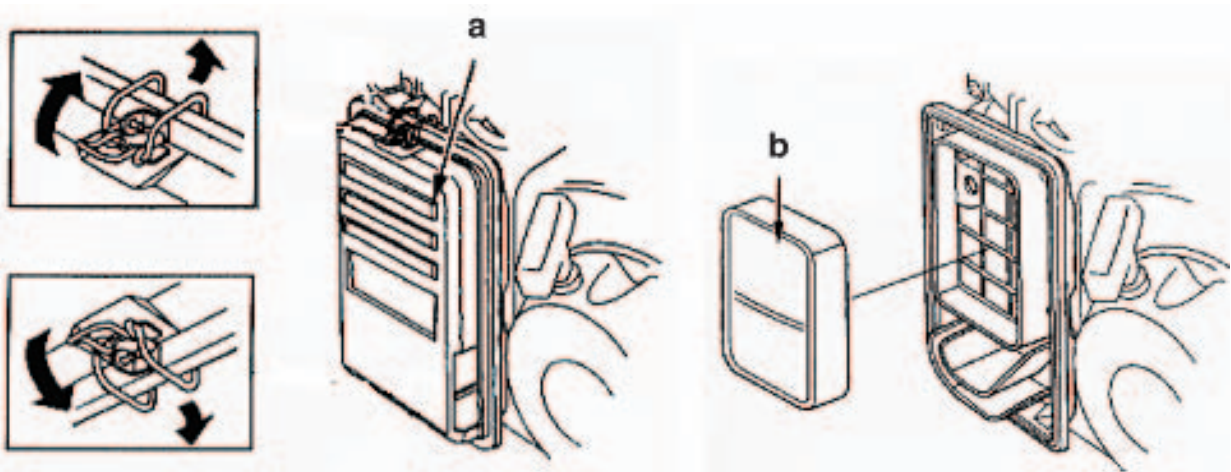

wc_gr002815

6.5 Spark Plug

Clean or replace the spark plug as needed to ensure proper operation. Refer to your engine operator's manual.



The muffler becomes very hot during operation and remains hot for a while after stopping the engine. Do not touch the muffler while it is hot.

Note: Refer to section *Technical Data* for the recommended spark plug type and the electrode gap setting.

- 6.5.1 Remove the spark plug and inspect it.
- 6.5.2 Replace the spark plug if the insulator is cracked or chipped.
- 6.5.3 Clean the spark plug electrodes with a wire brush.
- 6.5.4 Set the electrode gap **(a)**.
- 6.5.5 Tighten the spark plug securely.

NOTICE: A loose spark plug can become very hot and may cause engine damage.

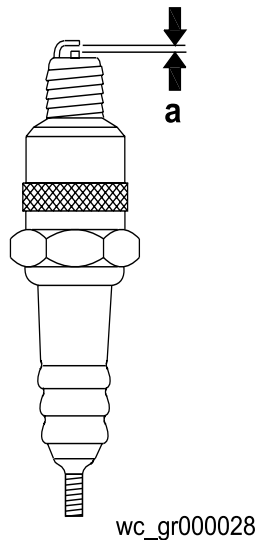

6.6 Cleaning the Sediment Cup

- 6.6.1 Turn the fuel valve off.
- 6.6.2 Remove the sediment cup **(a)** and the O-ring **(b)**.
- 6.6.3 Wash both thoroughly in a nonflammable solvent. Dry and reinstall them.
- 6.6.4 Turn the fuel valve on and check for leaks.

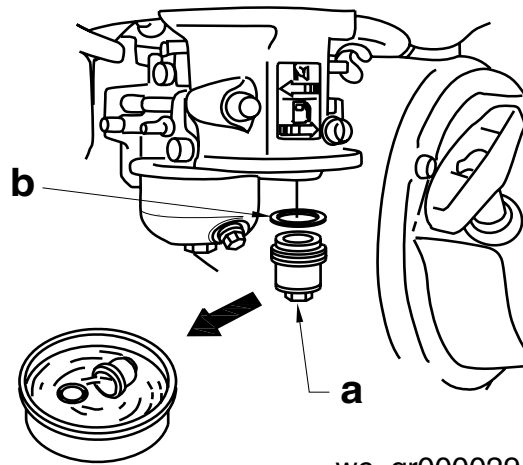

wc_gr000029

6.7 Carburetor Adjustment

- 6.7.1 Start the engine and allow it to warm up to operating temperature.
- 6.7.2 Set the pilot screw **(a)** two turns out. See *Note*.
- 6.7.3 With the engine idling, turn the pilot screw **(a)** in or out to the setting that produces the highest rpm.
- 6.7.4 After the pilot screw is adjusted, turn the throttle stop screw **(b)** to obtain the standard idle speed. See *Technical Data*.

Note: On some engines the pilot screw is fitted with a limiter cap **(c)** to prevent excessive enrichment of the air-fuel mixture in order to comply with emission regulations. The mixture is set at the factory and no adjustment should be necessary. Do not attempt to remove the limiter cap. The limiter cap cannot be removed without breaking the pilot screw.

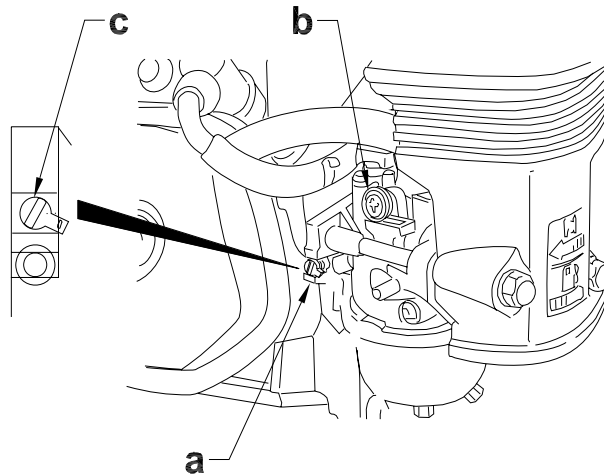

6.8 Adjusting Engine Speed

Generators require a fixed engine speed to maintain the correct voltage. Engine speed is controlled by a governor which automatically adjusts to varying loads on the engine to maintain a constant speed. There is no throttle control.

To set the engine to the proper speed:

Turn the speed adjusting screw **(b)** in or out to obtain a no-load speed. See *Technical Data*.

NOTICE: Setting the engine speed too high or too low may damage tools and other appliances attached to the generator.

6.9 Storage

Before storing the generator for a long period of time:

- 6.9.1 Close the fuel valve and remove and empty the sediment cup or fuel strainer.
- 6.9.2 Disconnect the fuel line from the carburetor. Place the open end of the fuel line into a suitable container and open the fuel valve to drain the fuel from the tank.



Gasoline is extremely flammable. Drain the fuel tank in a well-ventilated area. DO NOT drain the fuel tank in an area with flames or sparks.

- 6.9.3 Loosen the drain screw on the carburetor and drain any remaining fuel from the carburetor.
- 6.9.4 Change the engine oil.
- 6.9.5 Remove the spark plug and pour approximately 30 ml (1 ounce) of clean engine oil into the cylinder. Crank the engine a few turns to distribute the oil to the inside of the cylinder walls.
- 6.9.6 Pull the starter rope slowly until resistance is felt and leave the handle in this position. This ensures that the intake and exhaust valves are closed.
- 6.9.7 Store the generator in a clean, dry area.

6.10 Transport



Let the engine cool before transporting the generator or storing it indoors, to avoid burns or fire hazards.

When transporting the generator:

- 6.10.1 Turn the engine fuel valve to the OFF position.
- 6.10.2 Position the generator level to prevent fuel from spilling.
- 6.10.3 Secure the generator by tying it down with a suitable rope.



When transporting the machine by hand, be sure to employ manpower commensurate with the weight of the machine. To avoid back injury when lifting the machine, bend the knees to pick it up rather than bending your back only.

6.11 Troubleshooting

Problem / Symptom	Reason / Remedy
If engine doesn't start, check that:	<ul style="list-style-type: none"> • Engine switch is on "Start". • Fuel valves under fuel tank and on engine are open. • Fuel tank has fuel. • Choke lever is in correct position. Choke should be closed when starting a cold engine. • All loads are disconnected from generator. • Spark plug is in good condition. • Spark plug cap is tight. • Engine oil level is adequate.
If engine starts but there is no power at receptacles, check that:	<ul style="list-style-type: none"> • Circuit breaker is closed. • Connector from generator to control panel is tight.
If engine starts but runs erratically, check that:	<ul style="list-style-type: none"> • Hose routing from the fuel tank to the engine is correct. For proper operation, the hose must run through the bushing in the lifting bracket. Refer to the Parts Book for illustration.
If the GFCI trips when a load is connected, check that:	<ul style="list-style-type: none"> • The connected equipment may be wired incorrectly or faulty. Contact equipment supplier. • See section <i>Determining Power Requirements</i>.

6.12 Wire Colors

Wire Colors							
B	Black	R	Red	Y	Yellow	Or	Orange
G	Green	T	Tan	Br	Brown	Pr	Purple
L	Blue	V	Violet	Cl	Clear	Sh	Shield
P	Pink	W	White	Gr	Gray	LL	Light blue

Notes:

6.13 Electrical Schematic

Ref.	Description	Ref.	Description
A	Generator	D	Wacker Engine
B	Control box	E	Honda Engine
C	Electric start engines (GPS)		

Ref.	Description	Ref.	Description
1	Main stator winding 1	12	Engine ON / OFF switch
2	Main stator winding 2	13	Rectifier
3	Auto idle unit	14	Rotor winding/brushes
4	Main circuit breaker	15	Secondary (excitation) winding
5	Voltage selector switch (120/240V position shown)	16	DC winding
6	Duplex receptacle—120V	17	Automatic voltage regulator (AVR)
7	Twist-lock receptacle—120V	18	15A fuse (GPS only)
8	Twist-lock receptacle—120/240V	19	Ignition switch (GPS only)
9	Auto idle switch	20	GFCI
10	5A fuse	21	Neutral bond wire
11	Capacitor		

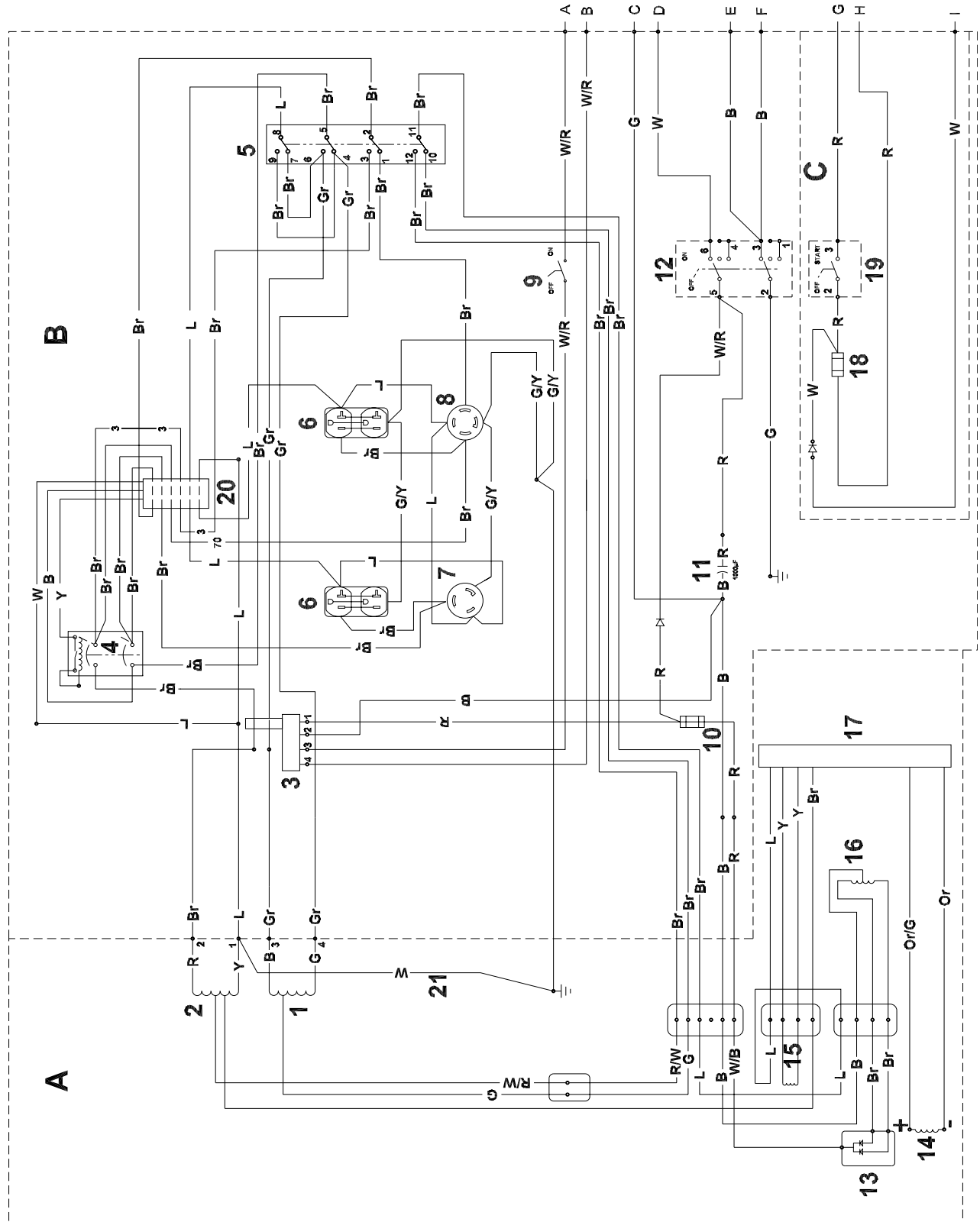

6.14 Electrical Schematic (CAN models only)

Ref.	Description	Ref.	Description
A	Generator	D	Wacker Engine
B	Control box	E	Honda Engine
C	Electric start engines (GPS)		

Ref.	Description	Ref.	Description
1	Main stator winding 1	13	Rectifier
2	Main stator winding 2	14	Rotor winding/brushes
3	Auto idle unit	15	Secondary (excitation) winding
4	Main circuit breaker	16	DC winding
5	Voltage selector switch (120/240V position shown)	17	Automatic voltage regulator (AVR)
6	Duplex receptacle—120V	18	15A fuse (GPS only)
7	Twist-lock receptacle—120V	19	Ignition switch (GPS only)
8	Twist-lock receptacle—120/240V	20	GFCI
9	Auto idle switch	21	20A circuit breaker
10	5A fuse	22	20A circuit breaker (GP 3800 CAN and GP4000 only)
11	Capacitor	23	30A circuit breaker (GP 5600/6600 CAN only)
12	Engine ON / OFF switch	24	Neutral bond wire

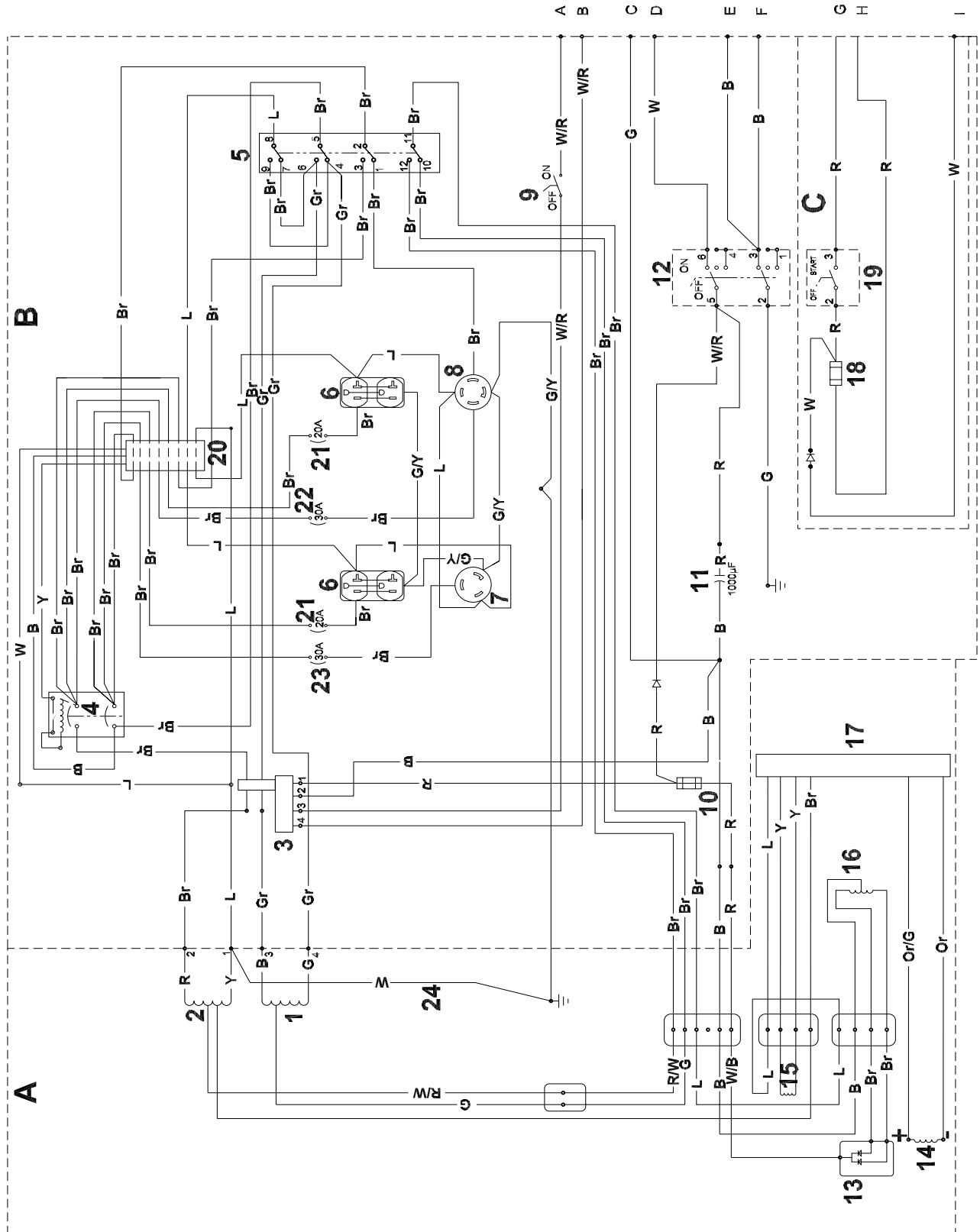

6.15 Engine Schematic

Ref.	Description	Ref.	Description
A	Generator	D	Wacker Engine
B	Control box	E	Honda Engine
C	Electric start engines (GPS)		

Ref.	Description	Ref.	Description
1	Idle solenoid	6	Solenoid (GPS only)
2	Fuel cut solenoid	7	Starter (GPS only)
3	Oil alert module	8	Charging coil (GPS only)
4	Oil level switch	9	Battery (GPS only)
5	Coil		

